

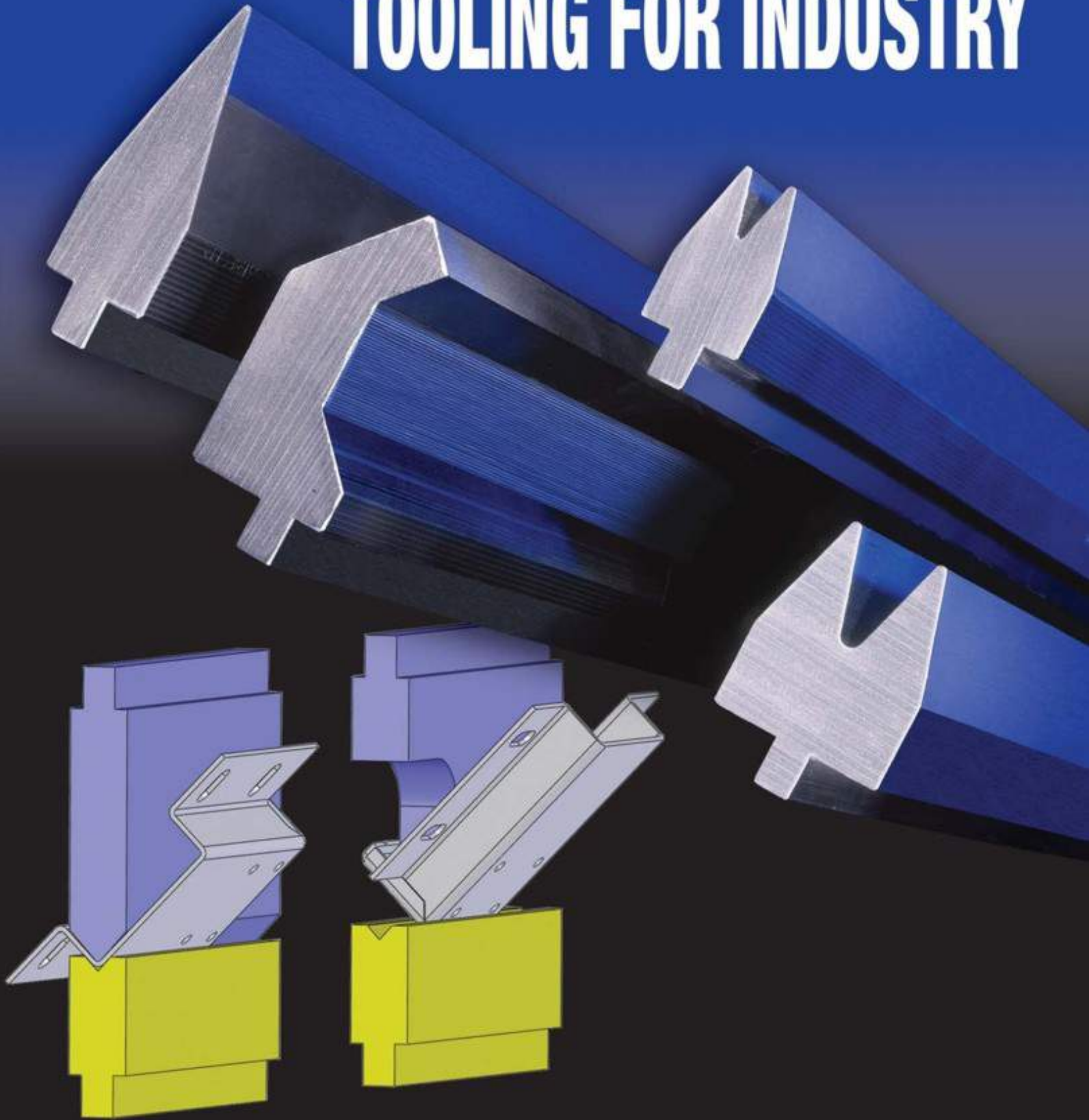

MECON

TOOLING FOR INDUSTRY





A leader in the field

To be a leader means setting the standards a notch higher than the competition. It means providing extra effort and quality without compromise.

Mecon Industries has been in the tooling and machine fabrication business since 1964.

We expanded to serve the demands of a steadily growing customer list. At present Mecon Industries has over fifty thousand square feet of floor space divided into four main shop areas: WELDING - MACHINING - PLANING and ASSEMBLY.

We take pride in offering the finest in equipment and workmanship with guaranteed quality, durability, reliability and cost effectiveness.

Mecon has a policy of continuous product research and improvement.

INDEX

How to order from Mecon	3
Brake press set-up aids	4
Box forming - gauging	5
Light gauge right angle bends	6
Heavy duty right angle bends	7
Acute angle bending dies	8
Hemming dies for light gauge material	8
Right angle "offset" die combination	9
Flattening die combinations	9
Mecon Industries in pictures	10-11
Punching plates - Riser blocks	12
Heavy duty punches and 4 way dies	13
Samples of special tools	14-15
Press brake bending chart	16
Notes of interest	17
Think safety	18
Mecon coil handling pictures	19



How to order dies from Mecon

STANDARD DIES

Specify: Catalogue number.
Length required to the nearest 2-foot increment.
Length tolerance + 2" - 0".
Standard dies with added length of 2" to 5" add 5%.
Over 5" next foot price.

SPECIAL PURPOSE DIES

Submit: Drawing and/or part samples.
Specify: Material type, thickness, and temper.
Press make, model, tonnage, stroke, shut-height, bed length.
Provide: Sample material if tryout is requested.

OPTIONS

Matched Shut Height: For multiple tool set up on the same press.
Tongue Types: Safety, metric, specials available at an additional charge.
Unless otherwise specified all dies are supplied with standard tongues.
Die Steel: Unless otherwise specified, all tools will be made from pre-hardened brake die steel at 265-280 Brinell.
Polished Finishes: For materials such as polished stainless, painted stock, "Finer polishing" priced on request.
Flame Hardening: The working radii of a punch or die can be hardened on request. Chrome plating and other hard coatings also available.
Tool Reconditioning: Machining service for tooling **up to 30 ft.**
Restoring to original specifications.
Redressing, radius and angle changes.
Crowning: Die riser blocks crowned to suit press deflection.



Brake press set up aids

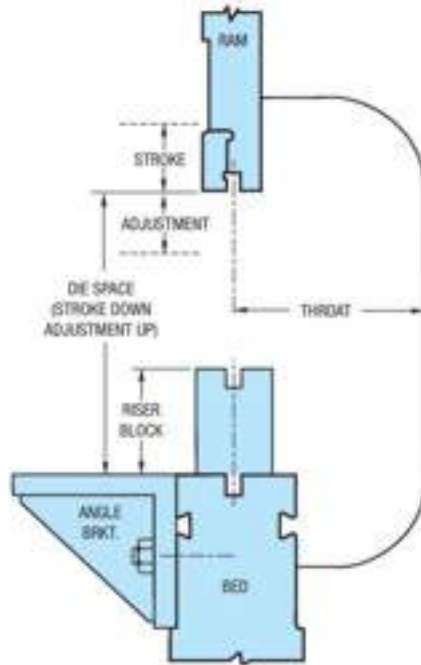

STANDARD GAUGE FOR STEEL SHEETS	
MANUFACTURER'S STANDARD GAUGE NO.	INCH EQUIVALENT THICKNESS
3	0.239
4	0.224
5	0.209
6	0.194
7	0.179
8	0.164
9	0.149
10	0.134
11	0.120
12	0.105
13	0.090
14	0.075
15	0.067
16	0.060
17	0.054
18	0.048
19	0.042
20	0.036
21	0.033
22	0.030
23	0.027
24	0.024
25	0.021

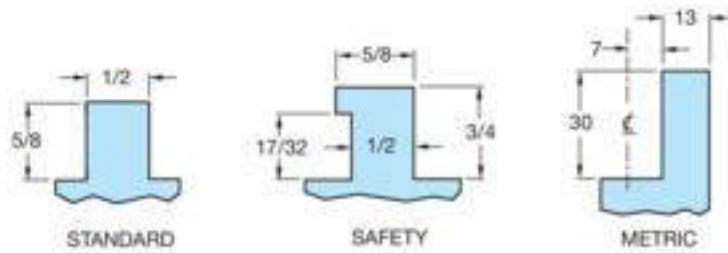

Common types of brake die tongues - others on request



Box forming

A box forming punch and die in 12" die space with ram width of 2 1/2". Graduations indicate minimum punch height required for various box depths.



Special clearance on ends of tools can be furnished to suit individual requirements.

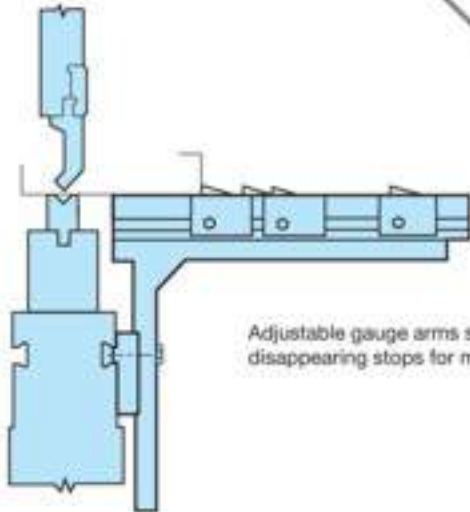

Adjustable gauge arms set up with disappearing stops for multiple bends.

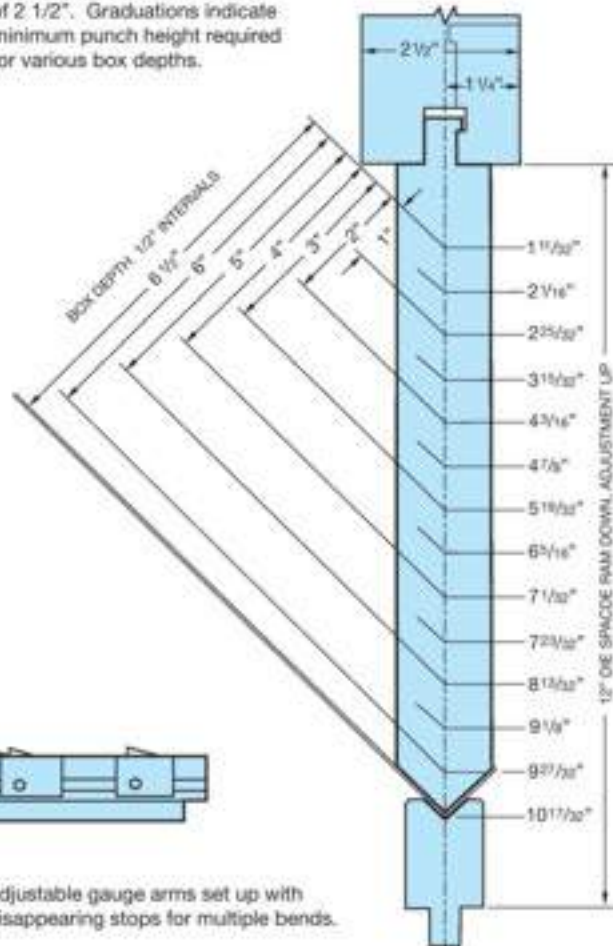



Light gauge right angle bends

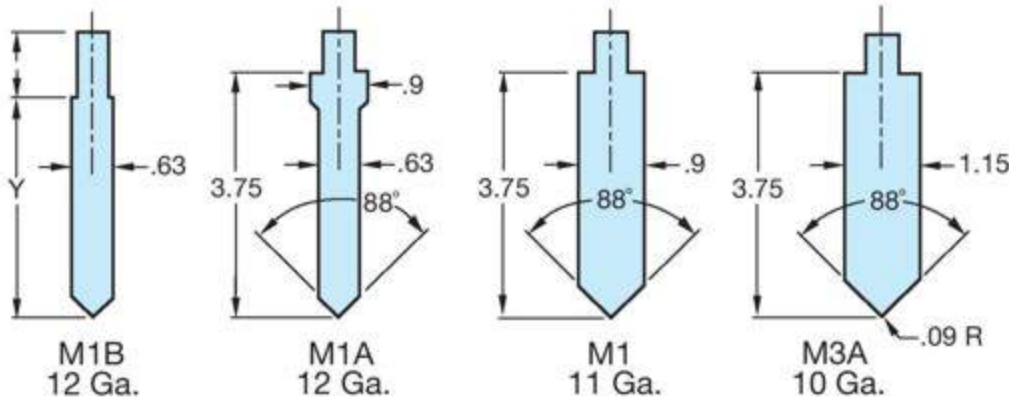

Use 88° punch and die combinations to reduce the tonnage required to form 90° bends and allow for springback.

Other punch and die angles can be supplied on request.

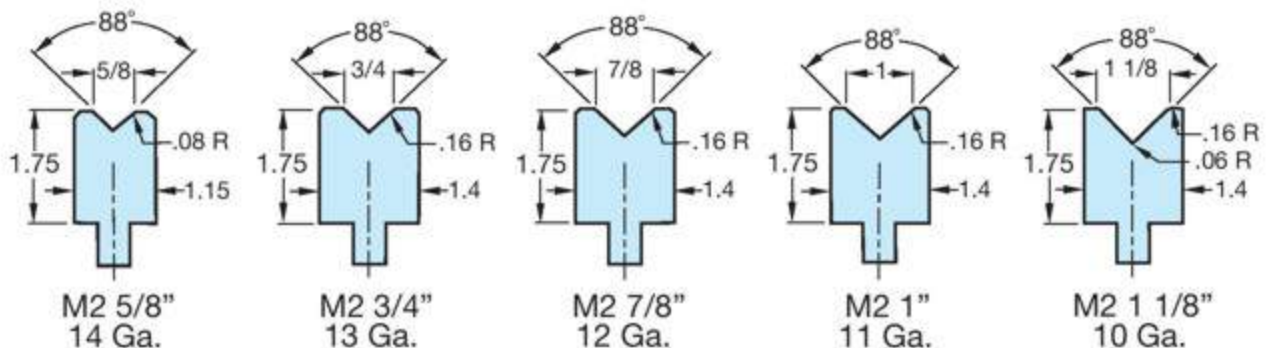
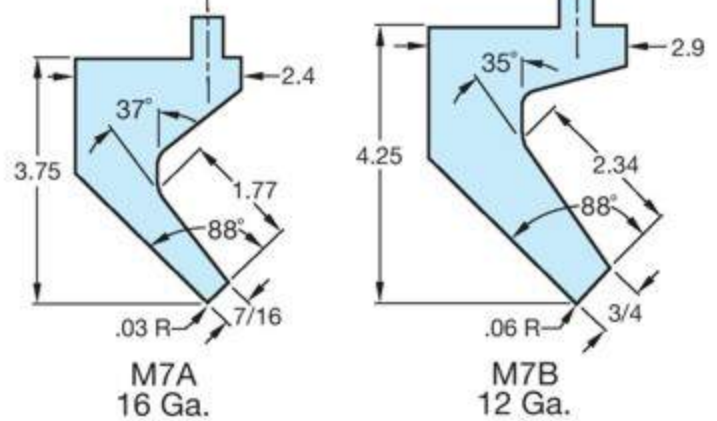
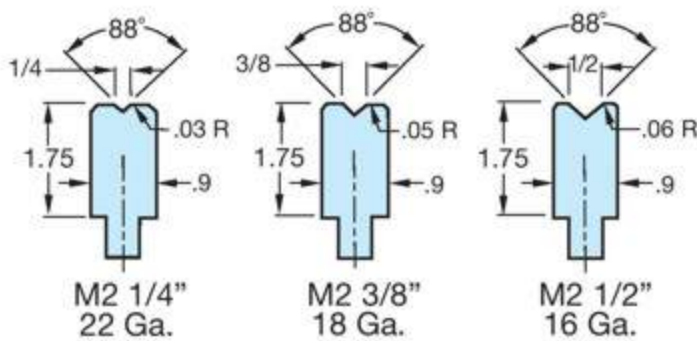
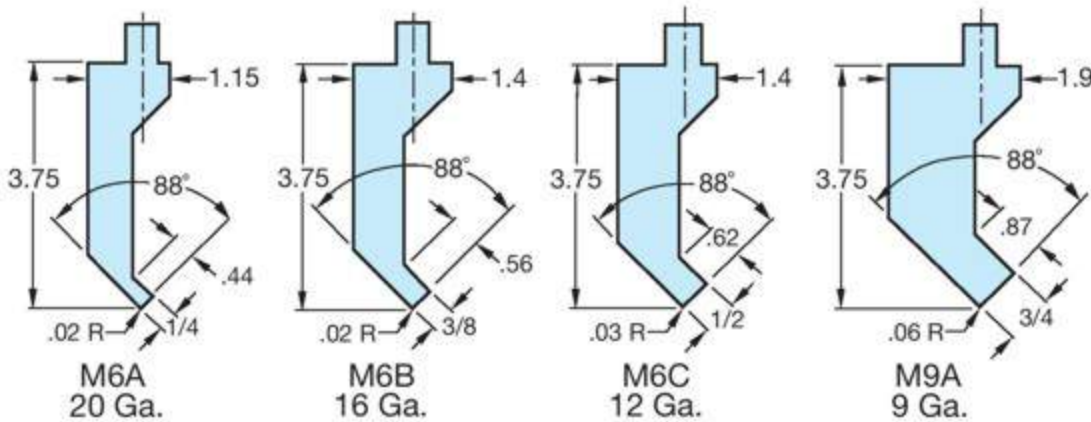

Note: Punch and die heights $\pm 1/8"$



Heavy duty right angle bends

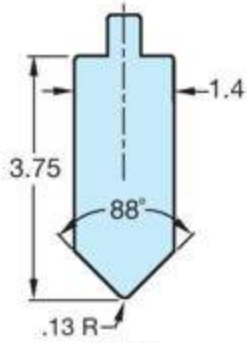

M3B
1/4"

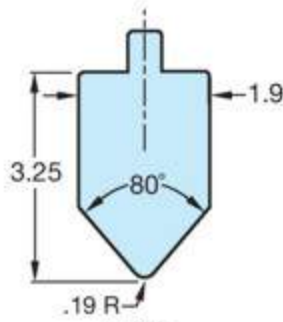

M3C
3/8"

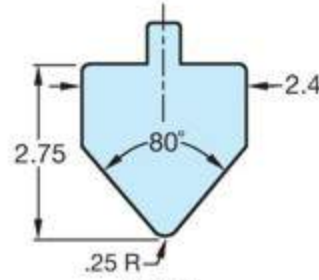

M3D
1/2"

Use air bending technique with these dies to reduce tonnage required on heavy gauge material.

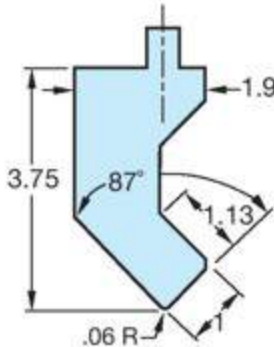

M9B
3/16"

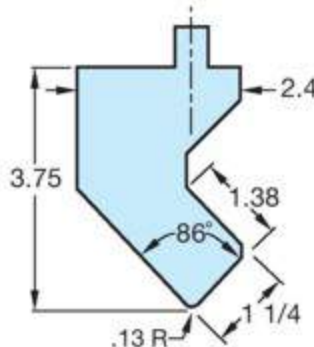

M9C
5/16"

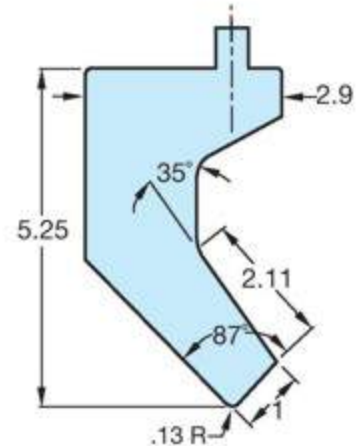

M7C
3/16"

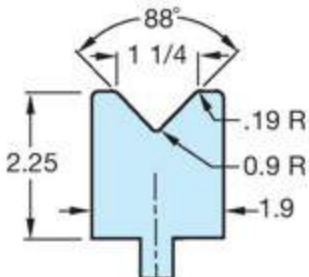

M4 1 1/4"
9 Ga.

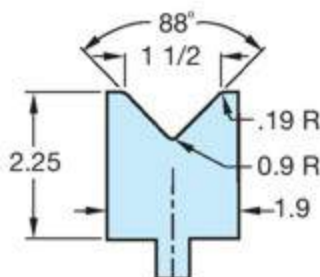

M4 1 1/2"
3/16"

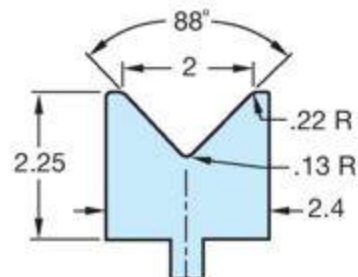

M4 2"
1/4"

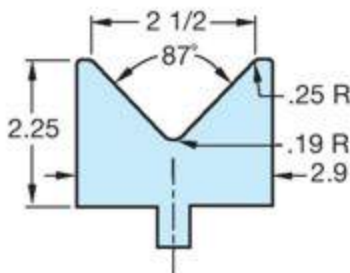

M4 2 1/2"
5/16"

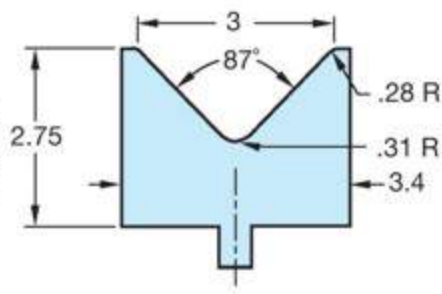

M4 3"
3/8"

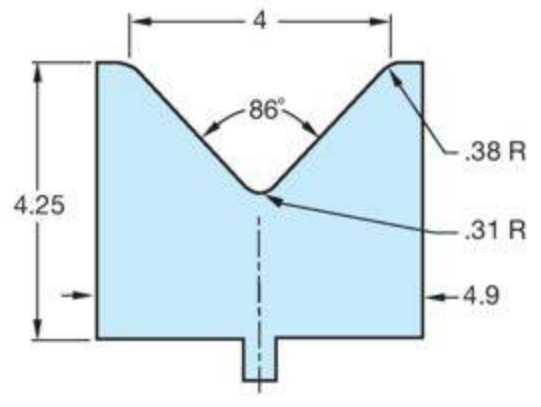

M4 4"
1/2"

Note: Punch and die heights $\pm 1/8$ "



Acute angle bending dies

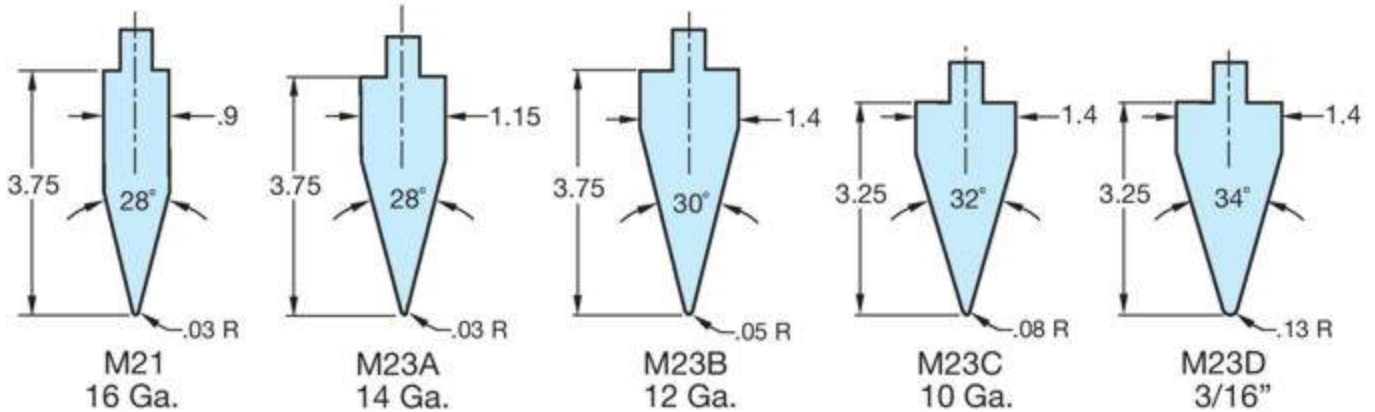

Use these dies to produce preliminary bend for hemming operation or air bend angles less than 90°.

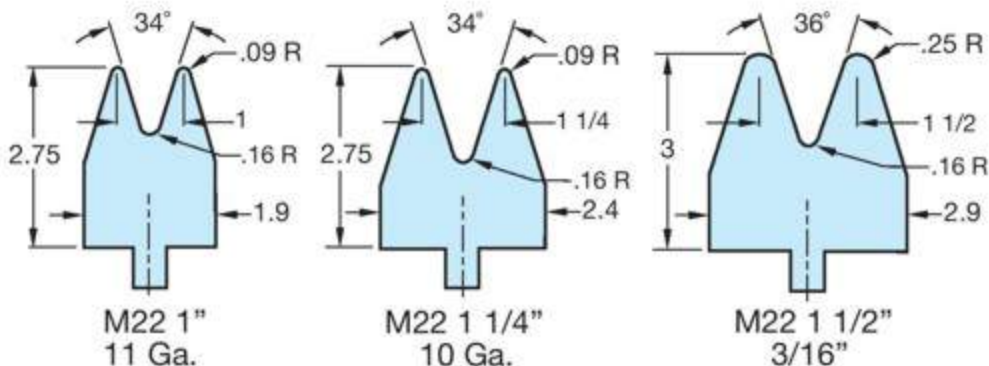
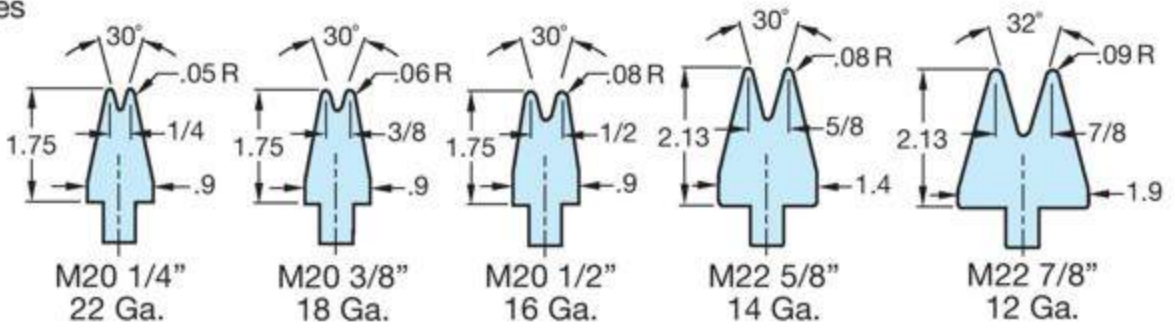

Regulating the depth that the punch enters the die opening varies the degree of the obtained bend.

Hemming die for light gauge materials

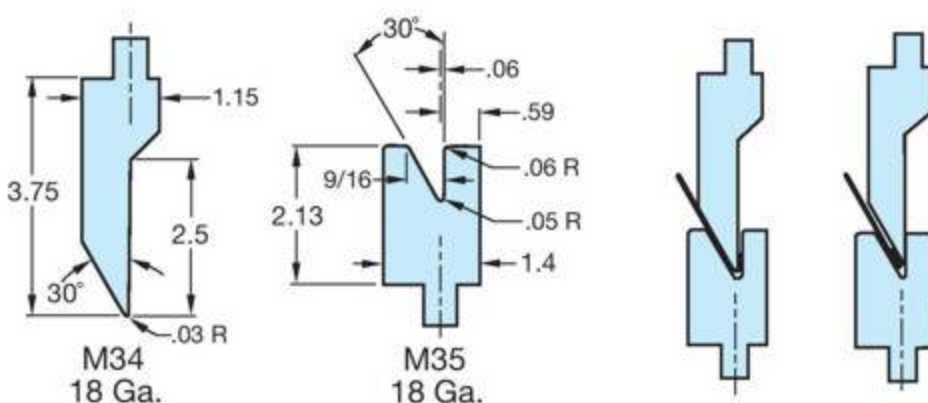

Use dies No. M34 M35 to produce hem in 2 hits in same die with one handling.



Right angle "offset" die combinations

Use these dies to produce close tolerance offset bends with reduced labour and handling time.

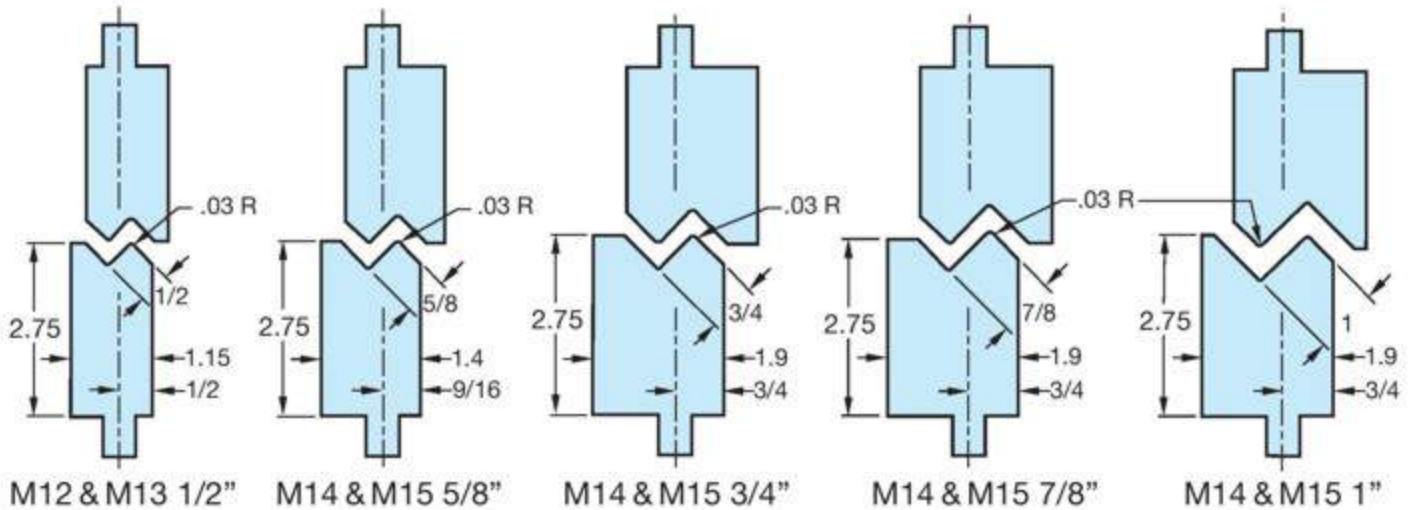
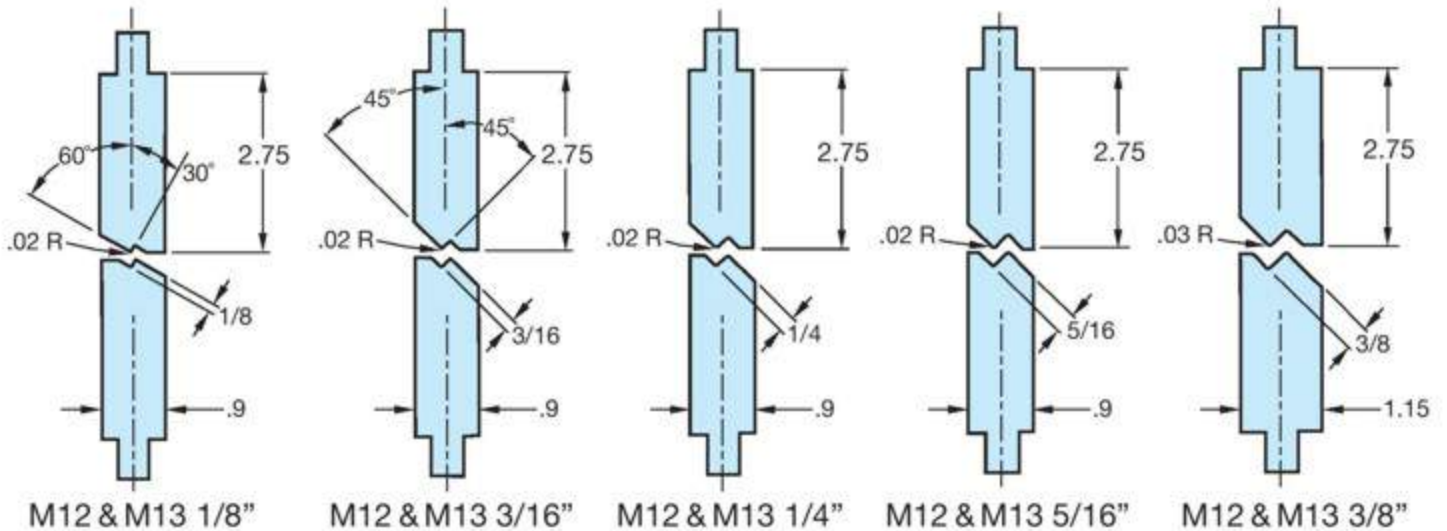

Flattening die combinations

Use these dies in pairs to produce hems or close previously formed acute angle bends to the desired degree.

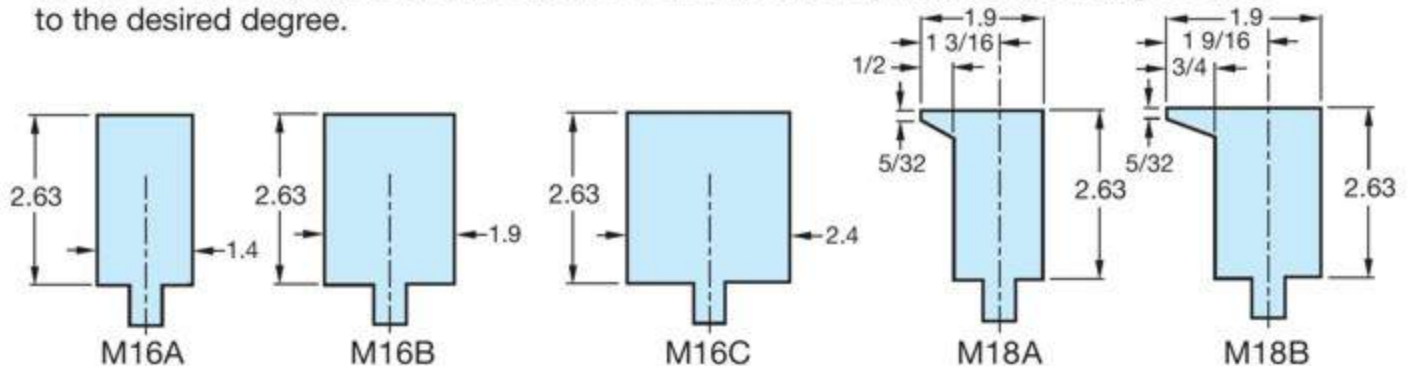

Note: Punch and die heights $\pm 1/8$ "



Our years of design and manufacturing experience provides us with the background to develop tools that work! We analyse the requirements and determine the most effective solutions to suit your production and budget requirements.

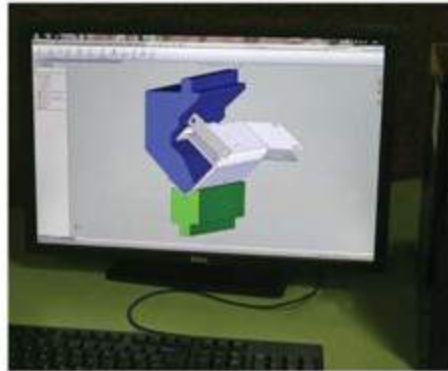
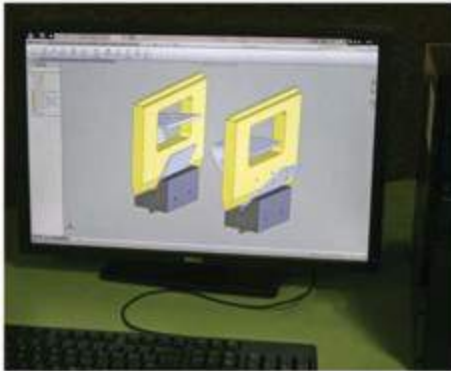

We can machine up to 30 feet (9.1 m) in one stroke and manufacture tooling for all types of presses. We also rework press rams and clamps. Mecon has been making quality tooling since 1964.





A large assortment of standard tooling is kept in stock for your convenience.



In-plant tool proving guarantees parts meet specifications.



Precision machining of complex dies is handled by experienced machine operators.

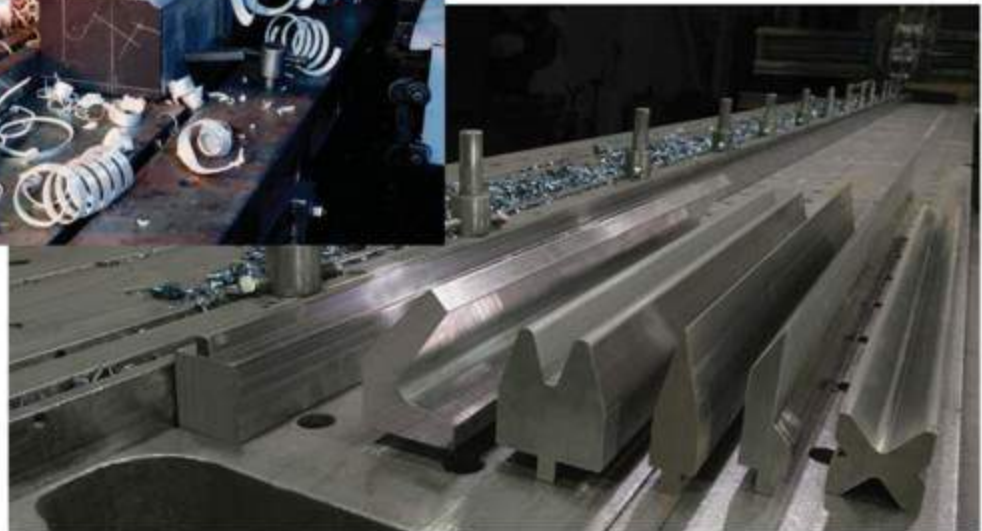



Punching plates

STRIKER PLATE

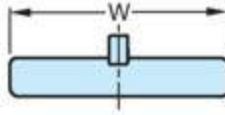

"T" SLOT PLATE

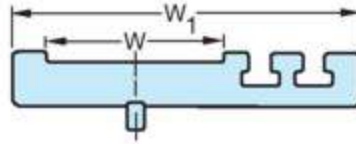

Riser blocks

Tongue or no tongue

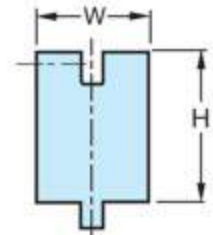

Tongue with window
No tongue with window

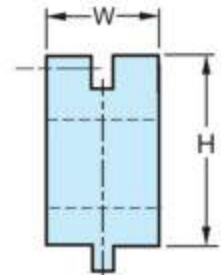
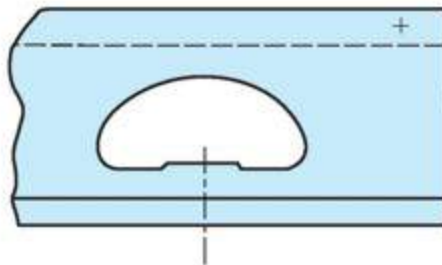

4 way die holder made to order
Centre groove optional
Bottom tongue optional

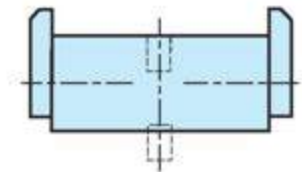

Press bed deflection compensating die holder
Multi point calibrating adjustment
Crown read-out indicators
pat.#1234039

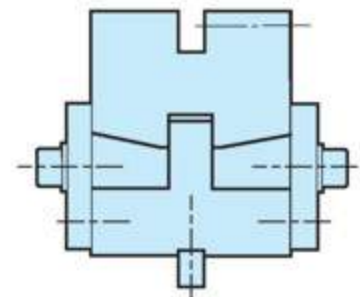



Heavy duty punches - Heavy duty 4 way dies

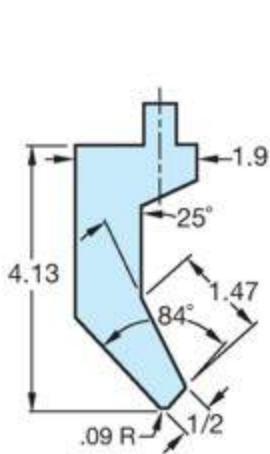

M8A
3/16"

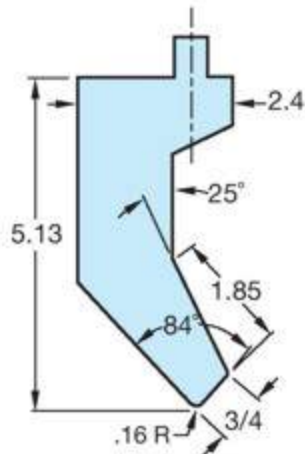

M8B
5/16"

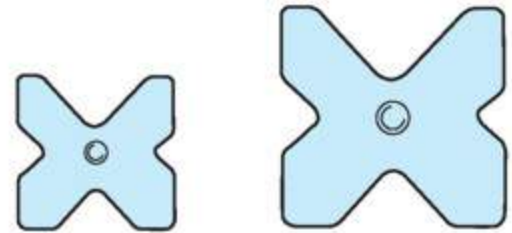

85° Vee groove standard.
Tapped holes provided at each end of die.

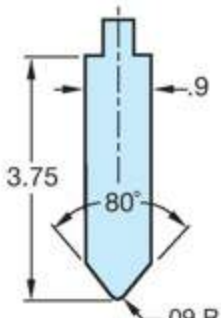

M27P

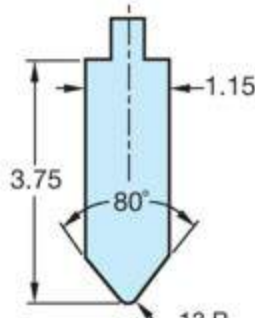

M32P

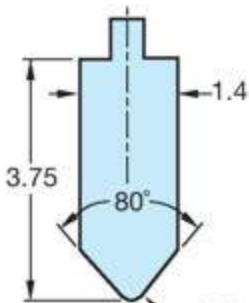

M37P

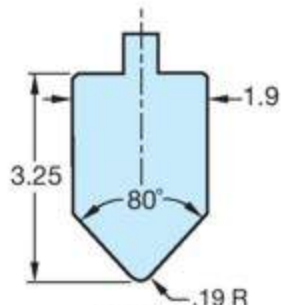

M3C

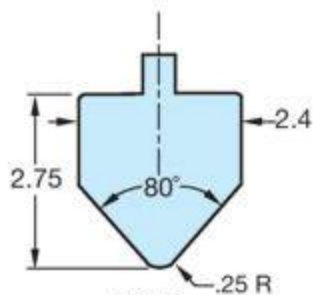

M3D

SQUARE SIZE	85° Vee opening			
	3/4	7/8	1 1/8	1 1/2
2.25	3/4	7/8	1 1/8	1 1/2
2.75	3/4	1	1 1/4	1 1/2
2.75	7/8	1 1/8	1 1/2	2
3.25	3/4	1	1 1/2	2
3.25	1	1 1/2	2	2 1/2
3.7	1	1 1/2	2	2 1/2
3.7	1 1/8	1 1/2	2	3
4.2	1	1 1/2	2	3
4.7	1 1/2	2	2 1/2	3
5.2	1 1/2	2	3	4
5.7	1 1/2	2	3	4

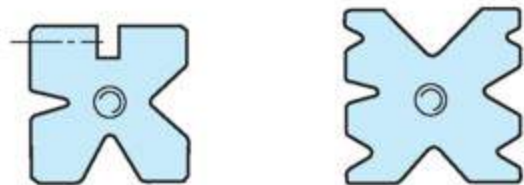

Other square and Vee combinations available on request.



Samples of special tools

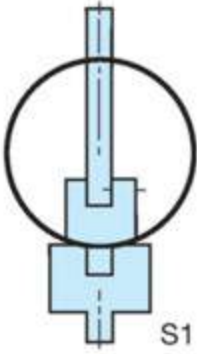

S1

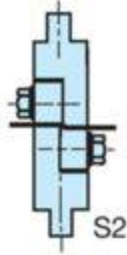

S2

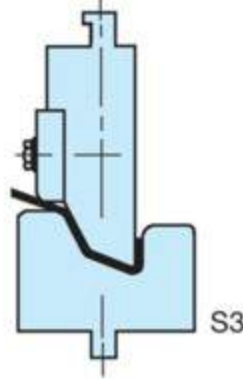

S3



S4

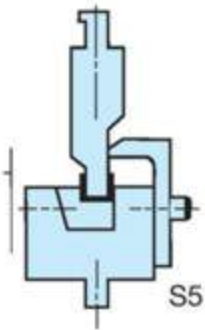

S5

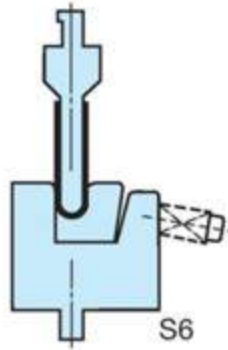

S6

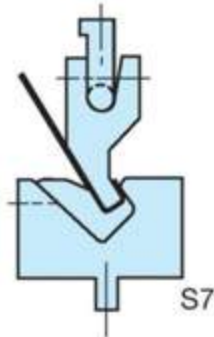

S7

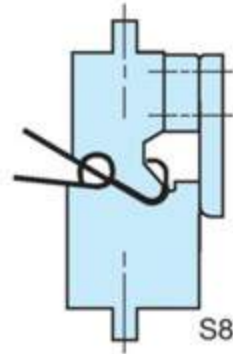

S8

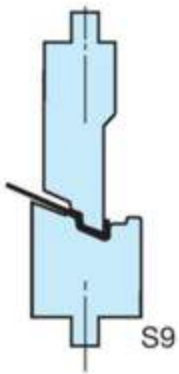

S9

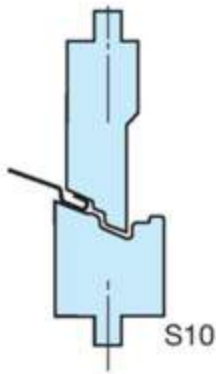

S10

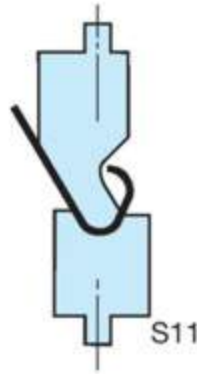

S11

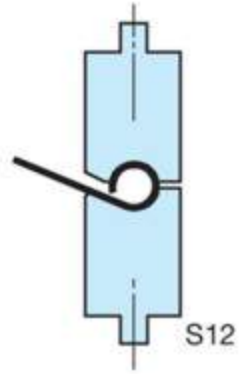

S12



Samples of special tools

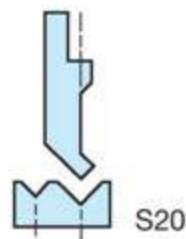
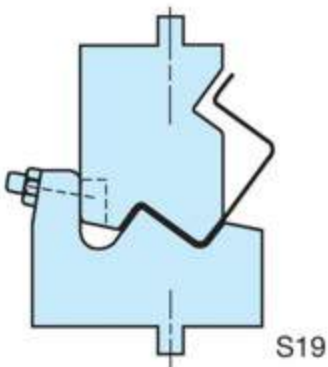
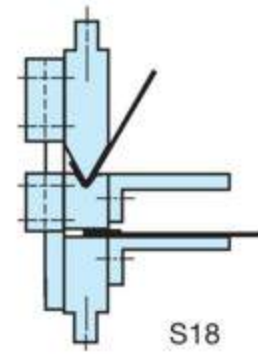
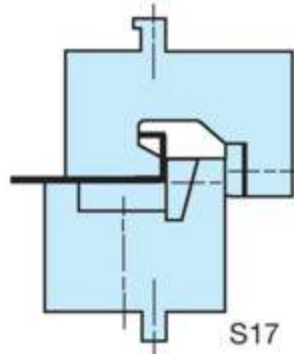
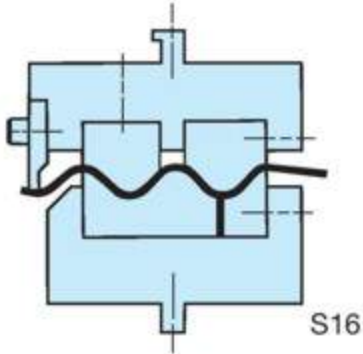
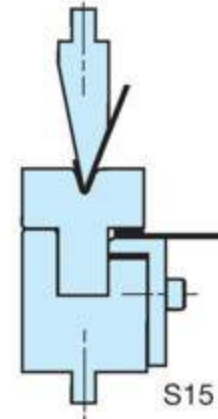
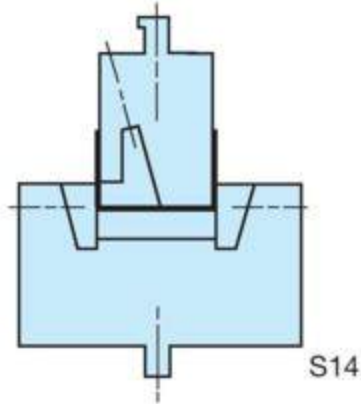
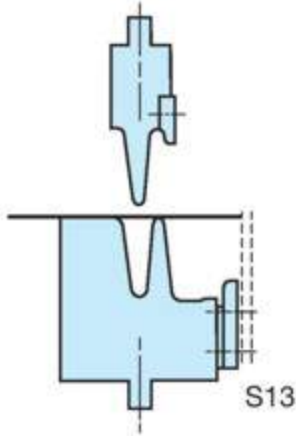

EUROPEAN STYLE TOOLING

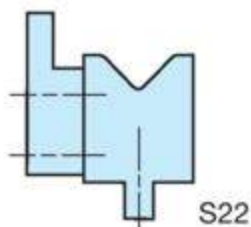
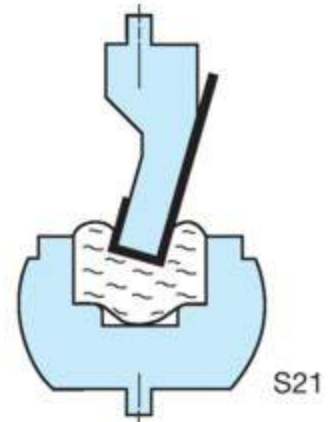

CUSTOM STOPS

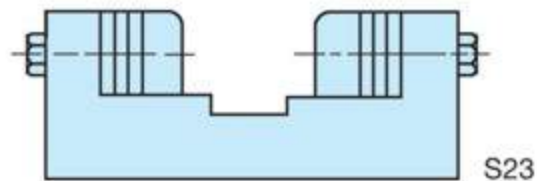

ADJUSTABLE DIES

URETHANE DIES



Brake press set up aids

Tons required per linear foot to bend mild steel plate having 60,000 P.S.I. tensile strength.
The tonnage indicated in **black boxes** are for die opening 8 times thickness of metal.

Thickness of metal

Width of die opening

Gauge	Inches	1/4"	5/16"	3/8"	7/16"	1/2"	5/8"	3/4"	7/8"	1"	1 1/8"	1 1/4"	1 1/2"	2"	2 1/2"	3"	3 1/2"	4"	5"	6"	7"	8"	10"	12"
20	0.036	3.1	2.3	1.7	1.4	1.1																		
18	0.048	5.3	4.0	3.0	2.5	2.2	1.7	1.3																
16	0.060	9.6	7.1	5.6	4.5	3.8	2.8	2.2	1.8	1.5														
14	0.075		11.9	9.2	7.6	6.3	4.7	3.5	3.0	2.5	2.1	1.8												
12	0.105				16.7	13.1	9.7	8.0	6.5	5.6	4.6	4.1	3.2											
11	0.120					19.2	14.2	11.1	9.0	7.5	6.3	5.5	4.4	2.9										
10	0.135						18.6	14.5	11.9	9.9	8.5	7.3	5.8	4.0										
3/16	0.188							27.4	23.1	19.3	16.4	14.3	11.2	7.5	4.4									
1/4	0.250								39.4	33.3	29.5	22.7	15.4	11.4	9.0	7.4	6.1							
5/16	0.313										50.4	39.8	27.0	19.7	15.3	12.7	10.5	7.7						
3/8	0.375											61.6	42.3	30.9	24.0	19.6	16.3	12.3	9.5					
7/16	0.438												61.7	45.8	35.4	28.6	24.4	17.3	14.8	11.2				
1/2	0.500													85.2	63.6	48.8	39.7	33.3	24.6	19.4	15.9	13.1		
5/8	0.625														110.0	86.2	70.0	58.3	43.1	33.3	27.4	23.3	16.9	
3/4	0.750															138.0	110.0	93.0	68.7	53.5	43.6	36.5	27.1	21.0
7/8	0.875																165.0	137.0	104.0	80.7	64.6	52.9	39.7	31.6
1	1.000																	197.0	143.0	113.0	91.2	76.2	56.3	44.2

With an 8 to 1 die ratio the inside radius of a right angle bend is approximately equal to the thickness of the material.
For other metals as compared to 60,000 P.S.I. tensile strength on chart.

soft brass 50% of pressure listed
soft aluminum 50% of pressure listed

stainless steel 50% more than listed
chrome molybdenum 100% more than listed

Bend Allowances for 90° Bends in Low-Carbon Steel and Aluminum

Metal thickness (t), in.	Bend allowance, in., for bends with inside radius (r) of:									
	1/32 in.		1/16 in.		3/32 in.		1/8 in.		1/4 in. (steel)	1/2 in. (steel)
	Steel	Al	Steel	Al	Steel	Al	Steel	Al		
0.032 ...	0.059	0.057	0.066	0.068	0.079	0.082	0.093	0.095	0.146	0.254
0.050 ...	0.087	0.078	0.101	0.091	0.114	0.105	0.129	0.118	0.168	0.276
0.062 ...	0.105	0.095	0.118	0.108	0.132	0.120	0.145	0.133	0.183	0.290
0.078 ...	0.128	0.116	0.142	0.131	0.155	0.144	0.169	0.157	0.202	0.310
0.090 ...	0.146	0.130	0.160	0.144	0.173	0.157	0.187	0.170	0.217	0.324
0.125 ...	0.198	0.175	0.211	0.189	0.224	0.203	0.243	0.216	0.260	0.367
0.188 ...	0.289	...	0.302	0.217	0.316	0.283	0.329	0.297	0.383	0.443
0.250 ...	0.382	...	0.395	...	0.409	0.365	0.424	0.378	0.476	0.519
0.313	0.488	...	0.501	...	0.515	...	0.569	0.676
0.375	0.593	...	0.607	...	0.661	0.768
0.437	0.699	...	0.752	0.860
0.500	0.845	0.952

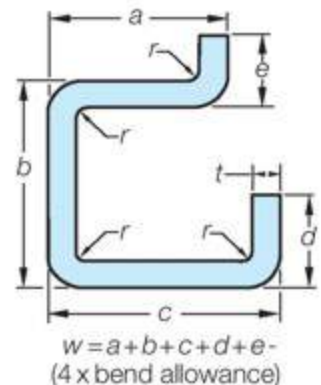
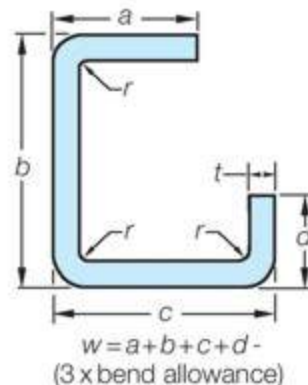
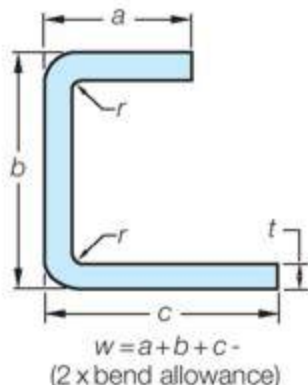
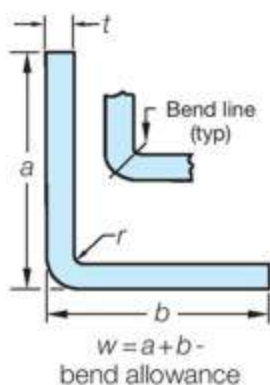



Notes of interest

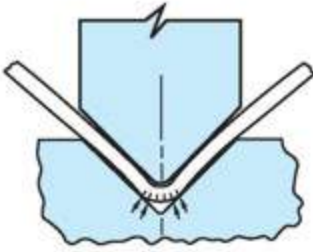

FRACTURING

When bending mild steel plate 1/2" thick and heavier or high strength materials, fracturing can be reduced by increasing die opening to 10 to 12 times material thickness. Increasing the punch radius also reduces fracturing.

Tonnage Increase: When making 90° bends the pressure to form the material rises rapidly to reach 85% of maximum when the material is bent up only 20°, and a maximum when the material is bent up 40°.

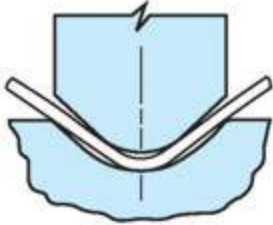

RADIUS DIES

When the radius exceeds four times material thickness, spring back must be compensated for in the dies. The large radius used to prevent fracturing may also create other problems such as, material pre-bending causing fluting and pulling away from the punch radius, thus requiring the radius to be coined at the bottom of the press stroke and adding to the tonnage. When forming exceptionally large radii, a bumping die will often prove more practical than a large deep die.

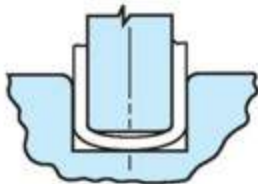

CHANNEL DIES

The corner sharpness requirements, and the flatness of the bottom section of the channel, have a direct bearing on the tonnage applied. Increasing corner radii reduces tonnage and helps in achieving a flatter bottom. Results are dependent on material which is uniform in thickness, temper and yield point.

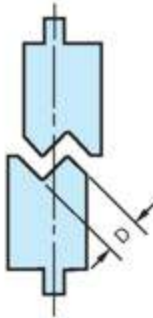

OFFSET DIES

The relation between depth of offset and metal thickness affects the accuracy of the 90° bends, good results (in material up to 18 gauge) can generally be obtained by bottoming if the depth of offset is 6 to 8 times metal thickness. The press brake tonnage requirements are approximately 5 times that needed for a single 90° air bend. When forming heavy gauge sheets, the depth of offset should be greater than 8 times metal thickness.

Tonnage requirements can be reduced (compromising on accuracy) by air bending rather than bottoming, and also by using larger radii on the forming points.

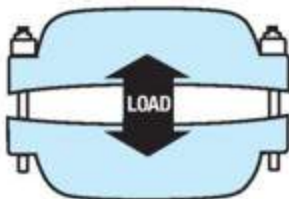

A simple view of press deflection

PRESS BRAKE DEFLECTION

A common problem with anyone using more than 1/2 the rated capacity of a press brake is deflection. The middle of the bed and ram spreads apart under load. This spreading can cause the angle in the middle of the part to be 1 to 3 degrees open compared to the ends.

There are a number of ways to solve the deflection problem.

- Shim the bottom die (crowning) using a roll of adding machine paper, start in the centre with a short piece, gradually increasing the length of the layers. The number of layers may be increased or decreased as required, 3 layers equals approximately .012".
- If you have dedicated tooling for a specific job, map out the deflection and machine it into the riser block.
- Purchase a "Mecon deflection compensating die holder".



Think Safety - Always

We strive to supply tooling which allows the production of parts in a safe manner.

As we have no control over how the dies are used, it must be understood, that the user is responsible to ensure that the proper methods, with due regard to the safety in operation, are followed. Safety and industrial standards must be considered to insure that the point of operation protection is effective.

Our dies are never intended to be used in equipment without a means provided for preventing hands or other parts of the body from entering or remaining in the die space during operation.

To prevent injury:

1. Require dies to be set only by a qualified die-setter who is safety conscious.
2. Insist on the die-setter being fully familiar with the press or machine manual.
3. Provide all point of operation guards or devices necessary - the essence of this being the avoidance of exposing any part of the operator's body to the closing of the machine or press.
4. Provide tools to insert material, to hold or remove parts if necessary, and to keep hands at a safe distance from the point of operation.
5. Insist on safety practices and procedures and enforce them day in and day out.
6. To ascertain proper set up, follow instructions referred to in the manual for the machine in which dies are being installed and operated.
7. Be certain that operators are trained in safety procedures, and arrange for periodic inspection to be sure operator is following said procedure.
8. Safety standard approved devices, such as pull backs, fences, infrared light curtain and controls should be made available for press equipment. Two-button operation may also be necessary in some instances.

Copyright ©2014 by Mecon Industries Limited.

Note: The printed material contained in this booklet cannot be reproduced without the written permission of Mecon Industries Ltd.

Specifications: We reserve the right to make modifications to design and dimensions to meet manufacturing conditions.



Another Side of Mecon - A Leader in the Design and Manufacture of Coil Handling Systems and Process Equipment

Mecon Industries has been consulting and serving the metal stamping industry since 1964 with high quality, innovative coil process equipment such as uncoilers, flatteners, straighteners, feeders, coil cars, punching presses, cutters, conveyors and collector systems.





Professional Engineers Ontario

"Authorized by the Association of
Professional Engineers of Ontario
to offer professional engineering services"



Mecon Industries Limited

**17 Malley Road
Scarborough, Ontario
M1L 2E4
Canada**

**Tel.: (416) 751-1901
Fax: (416) 751-6603
E-mail: mecon@mecon.com
Website: www.mecon.com**